

# Raising and control in Crow: Evidence from multiple person marking

Word count: 9118

**Abstract** Despite decades of intense research on raising and raising, not much attention has been paid to the properties of these phenomena in languages that exhibit a high degree of polysynthesis. The purpose of this paper is to contribute to the typology of raising and control by analyzing Crow (Apsáalooke), a highly polysynthetic Siouan language of Montana, USA. I argue that control and raising in Crow can be identified by studying the distribution of person marking. In Crow, multiple realizations of person marking are triggered when select morphemes combine with certain verbs. I claim that morphemes that trigger multiple person marking belong to the set of raising and control predicates. In particular, I adopt the view that raising and control are derived via A-movement of (pro)nominal arguments and that multiple person marking is the result of pronouncing all copies within a single A-movement chain. Therefore, this approach considers multiple copy spell-out as a type of clitic doubling (à la Harizanov 2014) that is decomposed into two parts: A-movement and m-merger.

**Keywords:** control; raising; polysynthetic languages; Crow; multiple person marking

## 1 Introduction

Raising and control phenomena have long been the subject of intense scrutiny in theoretical linguistics. Despite their surface structural similarities, raising and control constructions exhibit a number of differences in terms of their semantic and syntactic behaviors. Although initial accounts have attributed these differences to distinct syntactic mechanisms (Hornstein 1999; 2001; 2003; Boeckx 2000; Boeckx & Hornstein 2003; 2004; 2006; Boeckx, Hornstein & Nunes 2010; Hornstein & Polinsky 2010). In raising and control constructions, subjects are base-generated in a relatively low position, such as within embedded clauses, and undergo movement to a higher A-position.

As scholars investigate control and raising in a wider range of languages, they have found that these phenomena are subject to cross-linguistic variation. In raising and control constructions in English, only the higher copy is pronounced, while the anaphoric elements (i.e. trace or copy) are deleted. In contrast, Tsez deletes the highest copy in favor of pronouncing the lower copy (Polinsky & Potsdam 2002). The purpose of this paper is to contribute to the typology of control and raising by analyzing Crow (Apsáalooke), a highly polysynthetic, active-stative Siouan language spoken in Montana. Despite decades of intense research on control and raising, not much attention has been paid to the properties of these phenomena in languages that exhibit a high degree of polysynthesis, such as Crow (although see Potsdam & Polinsky 2012 on raising in Adyghe). In fact, much of early theorizing of raising and control has focused on data from English. Therefore, it remains unclear whether polysynthetic languages display properties that are similar or different to those reported for other non-polysynthetic languages.

The view I adopt in this paper is that raising and control in Crow are derived via A-movement. I will argue that pronominal subjects in control and raising in Crow undergo A-movement and morphological merger (henceforth referred to as m-merger; [Matushansky 2006](#)). I will show that unlike English or Tsez, raising and control clauses in Crow obligatorily pronounce both higher and lower copies – a case of multiple copy spell-out (or clitic doubling, à la [Harizanov 2014](#)). The main argumentation of this paper focuses on the distribution of A-set (or active) markers. In Crow, A-set markers may be realized multiple times when certain morphemes are present and I refer to the multiple realizations of person marking as *multiple person marking*.<sup>1</sup> While the first-person A-set marker occurs only once in (1a), it is realized twice in (1b). I claim that morphemes, such as *-iimmaachi*, that trigger multiple person marking belong to the set of raising and control predicates.<sup>2,3</sup>

- (1) a. **baa-lisshí-k**  
1A-dance-DECL  
'I danced'
- b. **baa-lisshí-\*(w)-iimmaachi-k**  
1A-dance-1A-will-DECL  
'I will dance'

Multiple person marking in Crow presents a puzzling array of patterns when we consider raising and control of more complex constructions and their behaviors with different classes of verbs. Specifically, raising constructions display an unergative-unaccusative split whereby multiple person marking is observed *only* across unergatives, but not unaccusatives, as in (3a). However, in control (3b) and causative constructions (3c), the distinction between unergative and unaccusative verbs in expressing A-set agreement morphology becomes neutralized and is observable for all verbs, including unaccusatives. The distinction between raising and control predicates in Crow relies on the inchoative marker *-dee* which appears only in control of unaccusatives; I analyze the presence of *-dee* in these constructions as a repair that feeds A-movement of the subject into the theta-position associated with the control predicate. Furthermore, the constructions in (b) as well as (c) gain the ability to exhibit multiple person marking when formed with raising and control predicates. I refer to this bundle of agreement phenomena as the *multiple person marking generalization*:

- (2) Multiple Person Marking Generalization: Only unergatives may exhibit multiple person marking in raising constructions, whereas all verbs show multiple marking of person in control and causative clauses.
- (3) a. Raising:
- (i) **baa-xalússhi-w-iimmaachi-k**  
1A-run-1A-will-DECL  
'I will run' (Unergative)
- (ii) **bii-hachk-íimmaachi-k**  
1B-tall-will-DECL  
'I will be tall' (Unaccusative)

<sup>1</sup> This phenomenon is also referred to as *multiple exponence*, *extended exponence*, and *exuberant exponence* (e.g., see [Harris 2017](#): 1-2).

<sup>2</sup> Note that in the data I do not gloss third person null morphemes, nor do I distinguish between affixes and clitics in the breakdown of the morphemes.

<sup>3</sup> The orthography employed in this paper here follows the conventions devised in part by Randolph Graczyk. See [Graczyk 2007](#): §2.1 for a detailed discussion of the orthography.

- b. Control:
- (i) **baa-xalússhi-wia-waa-k**  
1A-run-DESID-1A-DECL  
'I want to run' (Unergative)
  - (ii) **hachká-\*(wee)-wia-waa-k**  
tall-1A.INCHO-DESID-1A-DECL  
'I want to be tall' (Unaccusative)
- c. (Indirect) causatives:
- (i) **dii-chiwakíi-wa-hche-k**  
2B-pray-1A-CAUS-DECL  
'I made you pray' (Unergative)
  - (ii) **dii-ámmit-ba-hche-k**  
2B-fall-1A-CAUS-DECL  
'I made you fall' (Unaccusative)

To account for the Multiple Person Marking Generalization, I will demonstrate that multiple person marking is derived in exactly the same way across raising, control, and causative constructions: A-movement and m-merger. Specifically, the analysis hinges on the crucial assumption that a precondition for the (multiple) occurrence of A-set morphemes is agreement between a probe on Aux and a highest accessible DP argument. The DP that enters into an Agree relation with Aux is then able to receive nominative Case and undergo A-movement. Postsyntactically, pronominals undergo m-merge and become part of the verbal complex. In this way, multiple person marking is the result of pronouncing all copies that bear nominative Case within a single A-movement chain. Therefore, this approach captures the generalizations about raising, control and multiple person marking in Crow in a uniform way.

## 2 Multiple person marking in Crow

Crow is an endangered Siouan language spoken by approximately 2,000 speakers in south-central Montana (Graczyk 2007). Data used in this paper come from my fieldwork with 10 native speakers (4 female) aged 24–62 between 2017–2020 on the Crow Indian Reservation.<sup>4</sup> Crow is a head-final, head-marking language with an active-stative alignment expressed via its verb agreement system. In this section, I first describe the active-stative agreement system in Crow before providing an overview of the relevant patterns of multiple person marking in Crow.

In an active-stative language, verbs generally belong to one of two classes, *active* and *stative* verbs.<sup>5</sup> In general, the two classes are predictable based on their meanings. Active verbs tend to denote events with agentive subjects while stative verbs are commonly states with non-agentive subjects (Author 2019). In active intransitives, subjects are referenced with so-called A-set morphemes (4), whereas stative intransitives are marked using B-set markers (5). In an active transitive, as in (6), A-set marks subjects and B-set

<sup>4</sup> Some of the data collected between 2019-2020 come from elicitation sessions that were held virtually through video conferencing platforms with Crow speakers who are residing on the Crow Indian Reservation.

<sup>5</sup> Active-stative languages are also referred to as *split-intransitive*, *split-S*, and *agentive-patient*, and among others. For a more comprehensive list of terms variously used in the literature for this type of morphosyntactic alignment system, see Mithun 1991.

marks objects.<sup>6</sup> The A- and B-set morphemes are given in Table 1. Note that third person A- and B-set markers are phonologically null.<sup>7,8,9</sup>

- (4)    baa-lisshí-k  
       1A-dance-DECL  
       'I danced'
- (5)    bii-ámmichi-k  
       1B-fall-DECL  
       'I fell'
- (6)    dii-waa-láxpíi-k  
       2B-1A-hug-DECL  
       'I hugged you'

**Table 1:** A- and B-set agreement prefixes in Crow.

	A-SET	B-SET
1SG	baa-	bii-
2SG	daa-	dii-
3SG	∅-	∅-

Multiple person marking (MPM) in Crow is pervasive and is triggered by a variety of morphemes. I will argue that the morphemes that trigger MPM are in fact raising and control predicates. Table 2 provides a list of the raising and control predicates that will be discussed in this paper.

**Table 2:** Raising and control predicates in Crow.

CONTROL	<i>-bia</i> 'want to', <i>-isshi</i> 'wish to', <i>-dee</i> 'go (motion) to'
RAISING	<i>-iimmaachi</i> 'will, must', <i>-iishdaachi</i> 'should', <i>-iih</i> 'may, might', <i>-ii</i> 'will', <i>-bia</i> 'going to', <i>-dahku</i> 'keep on (iterative)', <i>-daachi</i> 'keep on (continuous)'

However, not all verbs display MPM even if morphemes that trigger it occur on the verb. The basic generalization is that in constructions with raising predicates, MPM occurs on active verbs but not stative verbs. One consequence of this is that only A-set morphemes may surface multiple times to cross-reference the same argument. In (7) and (8), *-iimmaachi*, *-dahku* and *-bia* are MPM-triggering morphemes and I will argue in this paper that they are raising predicates.<sup>10</sup> However, MPM is only found among active verbs in (7) but not stative verbs in (8).<sup>11</sup> Thus, the occurrence of MPM in raising constructions falls alongside the active-stative split.

<sup>6</sup> When A- and B-set morphemes co-occur, B-set morphemes must occur at the left-edge of the word, as in (6).

<sup>7</sup> In Crow, obstruents often undergo intervocalic laxing. Therefore, *b* and *d* may occur as *w* and *l* in environments where they occur between vowels.

<sup>8</sup> With exception of the first-person plural B-set morpheme, the plural is discontinuously marked as *-uu* that directly precedes the declarative marker. The first-person plural B-set morpheme *balee-* is a portmanteau consisting not only of person features but also number. The plural forms are not mentioned in the rest of this paper as they are not relevant to the current discussion.

<sup>9</sup> The A-set morphemes exhibit rampant allomorphy that is conditioned by the phonological shape of the verbal root it attaches to, whereas B-set morphemes are generally invariant.

<sup>10</sup> The morpheme *-bia* is ambiguous between a futurate meaning and a desiderate meaning. To distinguish between these two meanings, I notate futurate *-bia* as *-bia<sub>1</sub>* and desiderative *-bia* as *-bia<sub>2</sub>* in the data.

<sup>11</sup> In Crow, the so-called juncture morpheme *-a*, which is cognate with the continuative/contemporaneous morpheme in other Siouan languages, is a historical relic that is semantically vacuous and co-occurs with

- (7) a. **baa-xalússhi-w-iimmaachi-k**  
 1A-run-1A-will-DECL  
 ‘I will run’  
 b. **baa-lissá-a-wahku-k**  
 1A-dance-JUNCT-1A.CONT-DECL  
 ‘I keep on dancing’  
 c. **dii-waa-lít-bia<sub>1</sub>-waa-k**  
 2B-1A-hit-going.to-1A-DECL  
 ‘I am going to hit you’
- (8) a. **bii-hachk-íimmaachi-k**  
 1B-tall-will-DECL  
 ‘I will be tall’  
 b. **bii-awélit-dahku-k**  
 1B-fall-CONT-DECL  
 ‘I keep on falling’  
 c. **dii-ámmít-bia<sub>1</sub>-k**  
 2B-fall-going.to-DECL  
 ‘You are going to fall’

While the basic generalization about MPM in raising constructions is that stative verbs do not exhibit MPM, this is not the case for other types of constructions. When stative verbs appear in certain constructions, such as desideratives and causatives, the asymmetry between active and stative verbs becomes neutralized. First, in these constructions, A-set morphemes are used to index subjects of all verbs. Second, when MPM triggers are present, additional instances of A-set morphemes occur again for all verbs. In what follows, I describe the constructions that neutralize the agreement distinction between active and stative verbs starting with desideratives, which I argue are control predicates.

In Crow, there are two desiderative morphemes, *-bia* and *-isshi*. The former is used to express any kind of general desire, whereas the latter conveys a sense of uncontrollable urge and is often used with verbs of bodily excretion. When these desiderative morphemes attach to active verbs, we obtain an additional instantiation of A-set marking. In (9), *-bia* occurs with *disshí* ‘dance’, an active verb, and the additional A-set *-baa* appears as a suffix on the desiderative. However, MPM also occurs on stative verbs with desideratives. In (10), the occurrence of the desiderative on the stative verb *hachká* ‘be tall’ must be accompanied with the so-called inchoative morpheme *-dee*, which inflects for person of the subject. Like (9), an A-set morpheme referring to the first-person subject also appears on the desiderative. Because person features are encoded in two sites – the inchoative and the A-set marker – this construction also displays MPM.

- (9) **baa-lisshí-wia<sub>2</sub>-waa-k**  
 1A-dance-DESID-1A-DECL  
 ‘I want to dance’
- (10) **hachká-\*(wee)-wia<sub>2</sub>-waa-k**  
 tall-1A.INCHO-DESID-1A-DECL  
 ‘I want to be tall’

---

aspectual auxiliaries and the benefactive (cf. Graczyk 2007 who glosses *-a* as a continuative). The juncture morpheme triggers what is referred to in the Siouan literature as *ablaut*, whereby certain morphemes trigger a shift in quality of the preceding vowel. Ablaut has been described in many Siouan language, such as Crow (Graczyk 1996; 2007), the Dakotan languages (Shaw 1980; Albright 2002; Ullrich 2011), Hidatsa (Jones 1992; Park 2012), Mandan (Kasak 2019), and Quapaw (Rankin 1995), and among others.

Another construction in which the active-stative agreement split does not hold involves causative constructions. Crow distinguishes between direct and indirect causative constructions which are formed with *-aa* and *-hche*, respectively. The direct causative marker typically only occurs on stative verbs while the indirect causative may occur on active or stative verbs. Despite the morphological and semantic differences between the two causatives, there are similarities in how person marking surfaces in these constructions. First of all, both causatives introduce a subject argument and inflect for person of that argument. Second, both are able to exhibit MPM whenever a trigger appears in the construction.

This is exemplified in (11) and (12) for direct causatives. In (11a), *óosshi* ‘be cooked’ is a simplex stative intransitive with *xóoxaashe* ‘corn’ as its subject. With the direct causative *-aa*, as in (11b), an agent is introduced and is indexed via A-set marking. (12a) consists of a stative verb *úuchi* ‘be dry’ with the trigger *-bia* ‘going to’. The B-set marker is used to refer to the subject and we see that MPM does not surface at all. In contrast, in (12b), which contains a direct causative, person features are exponed twice, once on the direct causative and once as an A-set marker directly following *-bia*, both indexing the subject.

- (11) a. *xóoxaashe óosshi-k*  
 corn be.cooked-DECL  
 ‘The corn is cooked’  
 b. *xóoxaashe óosh-baa-k*  
 corn be.cooked-1A.CAUS-DECL  
 ‘I cooked the corn’
- (12) a. *bii-úut-bia<sub>1</sub>-k*  
 1B-be.dry-GOING.TO-DECL  
 ‘I am going to be dry’  
 b. *baaxúassee úut-baa-wia<sub>1</sub>-waa-k*  
 clothes dry-1A.CAUS-GOING.TO-1A-DECL  
 ‘I am going to dry the clothes’

Now, in indirect causatives, A-set morphemes are used to cross-reference the subject (i.e. the causer) while all other arguments are marked using B-set morphemes. In (13a), which contains the active verb *chiwakíi* ‘pray’, the A-set morpheme refers to the second-person subject, the agent of the praying event. With an indirect causative, as in (13b), the A-set morpheme refers only to the first-person causer while the B-set morpheme is used for the agent. In (14a), which contains the stative verb *ámmichi* ‘fall’, the B-set morpheme is used to mark the subject, the theme of the falling event. When an indirect causative attaches to this construction, as in (14b), the A-set marker refers to the causer while the B-set continues to cross-reference the theme. As in desiderative constructions, A-set morphemes must be used to refer to the subject of the entire clause, regardless of which class the verb belongs in.

- (13) a. **dah**-chiwakíi-k  
 2A-pray-DECL  
 ‘you prayed’  
 b. **dii**-chiwakíi-wa-hche-k  
 2B-pray-1A-CAUS-DECL  
 ‘I made you pray’

- (14) a. **dii-ámmichi-k**  
2B-fall-DECL  
'you fell'  
b. **dii-ámmi**t**-ba-hche-k**  
2B-fall-1A-CAUS-DECL  
'I made you fall'

As in the case of direct causatives, constructions that consist of an indirect causative morpheme and a trigger will multiply expone subject person features. The constructions in (15) and (16), which are similar to (13b) and (14b) but include the desiderative morpheme *-bia*, contain an active and stative verb, respectively. Yet, despite the different verbs that appear in these constructions, their agreement patterns are identical. The first-person A-set morpheme refers to the causer, whereas the B-set is used to refer to all other arguments. In addition, multiple instances of A-set are seen on the causative and on the desiderative which follows the causative.

- (15) **dii-chiwakí-wa-hche-wia<sub>2</sub>-waa-k**  
2B-pray-1A-CAUS-DESID-1A-DECL  
'I want you to pray (lit. 'I want to make you pray)'  
(16) **dii-ámmi**t**-ba-hche-wia<sub>2</sub>-waa-k**  
2B-fall-1A-CAUS-DESID-1A-DECL  
'I want you to fall (lit. 'I want to make you fall)''

Overall, if a given construction displays an active-stative agreement split, then MPM can only be observed across active verbs. Conversely, if a given construction references subject person features via A-set morphemes for both active and stative verbs, such as in constructions with desideratives and causatives, then MPM can be observed for all types of verbs; this is what I refer to as the Multiple Person Marking Generalization. These agreement patterns are summarized in Table 3. I argue that the generalizations about A-set marking and MPM are in fact two sides of the same coin in that both of them require establishing an Agree relation between Aux and a highest accessible DP argument. If there is no agreement between Aux and a DP, then neither A-set agreement nor MPM occurs. If agreement does indeed take place, then the DP receives a nominative Case feature. Furthermore, if Aux bears an EPP feature, the DP also moves to its specifier position. The higher DP copies then undergo m-merger postsyntactically and are rebracketed as part of a complex head.<sup>12</sup> Copies that bear nominative Case within the movement chain are then spelled out as distinct A-set morphemes. This approach therefore treats MPM as a type of clitic doubling that is decomposed into two parts: A-movement and m-merger (e.g. Harizanov 2014; Kramer 2014). This account forms the premise for the discussion in the following sections.

**Table 3:** Summary of A-set agreement patterns.

PROPERTY	SIMPLEX		CONTROL		CAUSATIVES	
	ACTIVE	STATIVE	ACTIVE	STATIVE	ACTIVE	STATIVE
A-set references subjects?	✓	✗	✓	✓	✓	✓
Multiple person marking?	✓	✗	✓	✓	✓	✓

<sup>12</sup> I assume here the Copy Theory of Movement (see Chomsky 1993; Nunes 1995; 1999; 2004, among others).

### 3 Raising and control in Crow

In a nutshell, raising, or more specifically raising-to-subject, has often been viewed as A-movement of a subject from an embedded clause, into a subject position within the matrix clause. Crucially, an external theta-role is assigned to the subject in the low position but not in the higher position. In (17a), the subject *the cat* is generated within the embedded clause and moves into the subject position of the matrix clause. However, the subject can also remain in-situ within the embedded clause, as in (17b). In such cases, the expletive subject *it* occupies the subject position of the matrix clause; the presence of the expletive subject indicates that the raising verb *seem* does not assign a theta-role to its argument.

- (17) a. The cat<sub>*i*</sub> seems *t<sub>i</sub>* to be out of the bag.  
 b. It seems that the cat is out of the bag.

Obligatory control, on the other hand, has been analyzed in different ways (see Landau 2013, Polinsky 2013, and Potsdam & Haddad 2017 for recent overviews of the various proposals within historical perspective). The classic view is to have the controller base-generated in the subject position of the matrix clause while a phonologically null element PRO occupies the subject position of the embedded clause, as in (18a). This empty category is coindexed with and bound by the controller in the main clause. An alternative view, dubbed Movement Theory of Control (MTC) and advanced by Hornstein (1999), analyzes control in terms of movement and has been a subject of ongoing debate (for criticisms against the MTC, see Culicover & Jackendoff 2001; 2006; Landau 2003; 2007; Bobaljik & Landau 2009; Wood 2012, among others; for works that advocate for the MTC, see Hornstein 2001; 2003; Boeckx 2000; Boeckx & Hornstein 2003; 2004; 2006; Boeckx, Hornstein & Nunes 2010; Hornstein & Polinsky 2010, among others). Under this account, the controller is generated in the subject position of the embedded clause and moves into the matrix clause, as in (18b), much like in a raising construction. The controller is therefore assigned theta-roles twice by the embedded verb and then the matrix verb, violating the Theta Criterion, which states that each argument must bear only a single theta-role and that each theta-role must be assigned to only one argument (Chomsky 1981: 35). Accordingly, Hornstein not only dispenses with the need for PRO, but he also rejects the Theta Criterion.

- (18) a. The cat wants PRO to be out of the bag.  
 b. The cat<sub>*i*</sub> wants *t<sub>i</sub>* to be out of the bag.

Raising and control are subject to cross-linguistic variation. Although English only spells out the higher copy, other languages may pronounce the lower copy or both; in the case of Crow, both copies are pronounced. The typology of raising and control phenomena is displayed in Table 4. An example of control constructions in which both higher and lower copies are pronounced occurs in San Lucas Quivini Zapotec, which is given in (19).<sup>13</sup> In (19), the subject *bxuuahaz* ‘priest’ is spelled out not only in the subject position

<sup>13</sup> As a terminological aside, control clauses in which both controller and controllee are pronounced have been referred to as ‘copy control’ in the control literature (e.g. Boeckx, Hornstein & Nunes 2008; Haddad 2009; Landau 2013: §4.4.2; Polinsky & Potsdam 2006; Potsdam & Haddad 2017). The term ‘copy raising’, formerly ‘Richard’, has been used primarily to refer to constructions where a subject appears in a non-thematic position with a pronominal copy in the non-thematic position (e.g. *The dog<sub>i</sub> seems like it<sub>i</sub> wants your attention*; see Potsdam & Runner 2001 and Asudeh & Toivonen 2012 for definitions on copy raising). Approaches have differed from analyzing these constructions as involving raising of the subject from its thematic position to the non-thematic position (e.g. Ura 1998) to involving base-generation of the subject in the non-thematic position (e.g. Potsdam & Runner 2001). Therefore, the use of the term does not necessarily

of the matrix clause, but also in the embedded clause. If instead the controlled element is a phonetically null PRO, one would predict that such constructions should not exist. Therefore, how exactly does the controlled element come to be pronounced in these types of control constructions?

- (19) *San Lucas Quivini Zapotec* (Lee 2003: 177, Ex.2)  
 R-cààa'z bxuuhahz [ch-iià bxuuhahz]  
 HAB-want priest IRR-go priest  
 'The priest wants to go'

**Table 4:** Typology of raising and control (Polinsky & Potsdam 2006).

Higher copy pronounced	Lower copy pronounced	Resulting structure
✓	✗	forward raising/control
✗	✓	backward raising/control
✓	✓	copy raising/control

One principled way of accounting for control constructions that spell out the lower copy, as in (19), is to adopt MTC in which the control dependency arises via A-movement. This approach has been proposed for control in San Lucas Quivini Zapotec (Boeckx, Hornstein & Nunes 2008), Telugu (Haddad 2009), Greek and Romanian (Alexiadou, Anagnostopoulou, Iordachioaia & Marchis 2010), and among others.<sup>14</sup> In (19), *bxuuhahz* 'priest' is base-generated within the embedded clause and moves to the subject position of the main clause. Thus, the controller and controlled element form the head and tail of the A-chain, and both elements are eventually spelled out. The account I just sketched can also be applied to raising constructions to explain how raising may come to pronounce both higher and lower copies. In this paper, I pursue an analysis along these lines to capture the generalizations about multiple person marking (MPM) in Crow. The core proposal is that MPM in Crow are instances of raising and control with *multiple copy spell-out*, in which higher and lower copies are pronounced, derived by means of A-movement (and m-merger).<sup>15</sup>

describe constructions that involve raising (see Polinsky & Potsdam 2006, who although generally use copy raising to involve movement, caution that some reported cases may in fact be imposters and not 'true' instances of copy raising). In this paper I use the somewhat clunkier phrase 'multiple copy spell-out derived via movement' and variants thereof to describe copy raising that involves both raising and copy control.

<sup>14</sup> Clauses in which both the controller and controllee may be pronounced appear to be typologically rare. To my knowledge, analyses of this phenomenon have only been provided by Boeckx, Hornstein & Nunes (2008) on San Lucas Quivini Zapotec (SLQZ) and by Haddad (2007; 2009) on Assamese and Telugu. However, there are several differences between the data they present and Crow. In Crow, the controllee must be spelled out as pronominal elements and they are not optional as is the case for SLQZ and Telugu. Moreover, overt full DPs cannot undergo multiple copy spell-out in Crow, whereas SLQZ and Telugu can. Finally, the control structures analyzed in Telugu by Haddad (2009) are adjunct control and both copies may be pronounced only when certain structural conditions are met (cf. Kissock 2014 for arguments against the existence of control in Telugu).

<sup>15</sup> A caveat about control constructions in Crow vis-à-vis current debates about MTC is in order. According to Pamela Munro, as cited in Polinsky & Potsdam (2006: 183), San Lucas Quivini Zapotec control constructions with overt nouns have the option of pronouncing either both copies or either the higher or lower copy. In contrast, control constructions that involve pronouns require both copies to be pronounced. As a result, control clauses in this Zapotec variety have been argued as compelling evidence in favor of the MTC. Control in Crow is similar to control in SLQZ in that pronominal A-set morphemes must also be expressed. However, the important difference is that in control constructions of Crow, overt nouns cannot be expressed more than once. It is therefore unclear to what extent control in Crow may be used as empirical support for the MTC.

Surveying raising and control predicates and their meanings across languages around the world reveals an emergent trend. Raising predicates tend to involve modal and aspectual verbs while control predicates often express intention and desire (Polinsky 2013). In Crow, morphemes that trigger MPM express meanings that resemble those of prototypical raising and control predicates found in other languages. In what follows, I present an analysis in which constructions that consist of modal and aspectual auxiliaries involve raising and those with desiderative or andative morphemes involve control. The list of morphemes belonging to each category are displayed in Table 5.<sup>16,17</sup>

**Table 5:** Raising and control predicates in Crow.

RAISING	MODAL	<i>-iimmaachi</i> ‘will, must’, <i>-iishdaachi</i> ‘should’, <i>-iih</i> ‘may, might’, <i>-ii</i> ‘will’
	ASPECTUAL	<i>-bia</i> ‘going to’, <i>-dahku</i> ‘keep on (iterative)’, <i>-daachi</i> ‘keep on (continuous)’
CONTROL	DESIDERATIVE	<i>-bia</i> ‘want to’, <i>-isshi</i> ‘wish to’
	ANDATIVE	<i>-dee</i> ‘go (motion) to’

### 3.1 Unaccusativity and active-stative agreement

Before we turn to the discussion on raising and control in Crow, I provide an overview of the mechanisms underlying the basic active-stative agreement system in the language. Active intransitives behave syntactically like unergatives and stative intransitives behave like unaccusatives (Author 2019). One diagnostic involves noun incorporation, which is attested only for nouns that are objects of transitive verbs, as in (20a), and nouns that are subjects of stative intransitives, as in (20b).

- (20) a. Logan bishka-lúupia-k  
Logan dog-dislike-DECL  
‘Logan dislikes dogs’  
b. ilúk-hilahp-ak  
meat-scarce-SS  
‘meat is scarce’ (Graczyk 2007: 282)

Active intransitives, on the other hand, do not allow incorporation of their subjects and attempts to elicit such constructions have been unsuccessful. What this test indicates is that subjects of stative intransitives are in a similar syntactic position to those of objects of transitive verbs. In addition, this position allows for incorporation into the verb. Based on the facts about noun incorporation in Crow, I analyze active intransitives as unergatives

<sup>16</sup> The list of MPM triggers in Table 5 is not exhaustive. In addition to the applicative constructions which display MPM, there is a number of morphemes that are not considered in this paper, including other aspectual auxiliaries *-datchi* ‘continue (by mouth)’, *-dawi* ‘begin to’, and *-koowee* ‘finish’, and among others. I surmise that the analysis for the aspectual auxiliaries analyzed in this paper largely applies to these other aspectual auxiliaries. As for the applicatives, more work is still needed to determine how they fit in with respect to the analysis of MPM.

<sup>17</sup> Surprising, the suffixes *-chichee* and *-ta* meaning ‘seem’, ‘appear’, or ‘resemble’ do not participate in MPM. The former shares form and function with the stative transitive verb *chichée* ‘resemble’ which marks both of its arguments with B-set morphemes. Like most of the other MPM triggers, it is likely that the suffix *-chichee* grammaticalized from the stative transitive. However, unlike the other morphemes which come from active verbs and kept their original inflections, *-chichee* appears to have lost them. It is unclear why *-ta* does not display any inflections, but I speculate that its historical development also plays an important role.

and stative intransitives as unaccusatives. Their structures are given below in (21) and (22).<sup>18</sup>

- (21) Unergative (active intransitive)      (22) Unaccusative (stative intransitive)



The unergative/unaccusative distinction is especially relevant to the discussion on raising because in simplex constructions, MPM only occurs on unergatives but not unaccusatives. While the realization of A-set morphemes appears to be a precondition for MPM, I argue that it is actually the underlying mechanisms that give rise to A-set that also governs whether or not MPM will surface. In particular, I pursue an analysis that leverages the structural differences between unergatives and unaccusatives. I assume that the basic clause structure of Crow includes an AuxP that sits directly above vP and I analyze A-set marking as a response to Agree between a  $\varphi$ -probe on Aux with the highest accessible goal. On the other hand, B-set agreement is the result of Agree between a  $\varphi$ -probe on  $v$ .<sup>19</sup> These assumptions allow us to capture the agreement asymmetry between unergatives and unaccusatives, which are schematized in (23) and (24).<sup>20</sup>

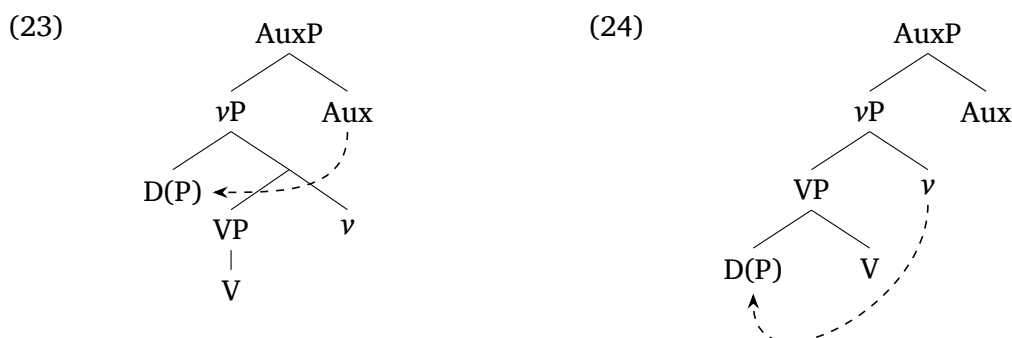

In (23), which represents an unergative, Aux probes and agrees with the highest DP argument, the external argument. In (24), which represents an unaccusative,  $v$  agrees with the internal argument and copies its  $\varphi$ -features. Why is it the  $v$  and not Aux that enters into an Agree relation with the VP-internal DP? Following Legate (2003) and Deal (2009), I assume that unaccusative  $v$  is a phase head and agreement between Aux and the internal argument is simply not possible. By the time Aux is merged into the structure, VP, the

<sup>18</sup> In the rest of this paper, I refer to active intransitives as unergatives and stative intransitives as unaccusatives.

<sup>19</sup> There is a small set of stative transitive verbs in Crow, which, unlike active transitives, mark both arguments with B-set morphemes. While they are not discussed in this paper, they provide some support for an analysis of  $v$  as an insatiable probe that interacts with all DP goals within its search domain (Clem 2019; Deal 2020). I analyze stative transitives as consisting of two internal arguments within the VP domain. Under an account in which  $v$  targets only the highest accessible DP, one would expect only a single B-set morpheme in stative transitives. Thus,  $v$  must be able to probe and interact with both DPs within its search domain. However, since insatiability does not figure into the arguments in this paper, I will continue to analyze  $v$  under the standard approach.

<sup>20</sup> The CP layer is omitted for simplicity's sake.

complement of the phase head  $v$ , has been sent to PF and LF (see Chomsky 2000; 2001 on the *phase impenetrability condition*, henceforth abbreviated as PIC). Therefore, the differences between agreement in unergatives and unaccusatives stem from what probes and where the subject DP is located within the clausal spine. In unergatives, Aux agrees with the subject, an external argument, which occupies Spec $v$ P; since Spec $v$ P is at the edge of the phase, this position is accessible to the Aux probe. In unaccusatives,  $v$  agrees with the subject, an internal argument, which resides within the VP.

Upon interacting with Aux, the DP in unergatives receive a nominative Case feature. This point is crucial since it is precisely these features that allow unergatives to index subjects with A-set morphemes. The view that I adopt here is that agreement morphemes in Crow are essentially pronominal arguments. The vocabulary items for A-set and B-set morphemes are given in (25) and (26). Unlike the B-set morphemes which are only specified for person features, the A-set morphemes are also specified for nominative Case features; in the elsewhere, default condition, such as the case for third person DPs, a phonologically null element is inserted. How does the agreement morpheme show up in the verbal complex despite being realized on D? I assume that D(P)s that occupy a specifier undergo *m-merger* with the head of that specifier. Simply put, m-merger is a postsyntactic operation (preceding Vocabulary Insertion) that rebrackets a Spec-Head configuration as a single complex head (Matushansky 2006). By rebracketing the head and its specifier, m-merger feeds affixation of these adjacent elements. This morphological operation is illustrated in (27). In (27a), Y is an element occupying SpecXP. When m-merger is applied, Y is rebracketed as part of the complex X head, as in (27b).

(25) A-set morphemes

- a. [1, NOM]  $\leftrightarrow$  /baa/ / D
- b. [2, NOM]  $\leftrightarrow$  /daa/ / D

(26) B-set morphemes

- a. [1]  $\leftrightarrow$  /bii/ / D
- b. [2]  $\leftrightarrow$  /dii/ / D

(27) M-merger

$\Rightarrow$

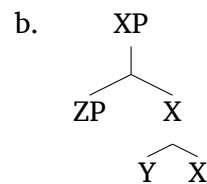
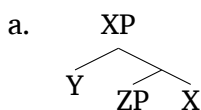

To summarize, A- and B-set agreement are derived from differences in syntactic positions. Subject DPs in unergatives occupy Spec $v$ P and form an Agree relation with Aux which results in A-set marking while subject DPs in unaccusatives, which results in B-set marking, are internal arguments that are inaccessible to the probe on Aux. Having laid out the necessary groundwork, we are now able to capture the generalization in which unergatives exhibit MPM, whereas unaccusatives do not (see Table 6). What I argue is that structural differences once again have a crucial role to play. Whereas the spell out of A- or B-set morphemes are dependent on probes and their search domains, MPM hinges on whether movement to certain landing sites is permitted. The analysis of MPM which I take up in the following section suggests that the occurrence of MPM is a consequence of clitic doubling (i.e. A-movement and m-merger).

**Table 6:** Summary of agreement patterns in simplex clauses.

PROPERTY	SIMPLEX	
	UNERGATIVE	UNACCUSATIVE
A-set references subjects?	✓	✗
Multiple person marking?	✓	✗

### 3.2 Raising

An additional distinction between unergatives and unaccusatives is that only unergatives may exhibit MPM with certain morpheme combinations. I analyze the morphemes that demonstrate this dichotomy as raising predicates. In (28) and (29), which consist of an unergative and an unaccusative, the so-called modal auxiliary *-iimmaachi* ‘will, must’ attaches to the verb roots *xalússhi* ‘run’ and *hachká* ‘be tall’. However, MPM is only observed in the former case. Furthermore, when *-iimmaachi* attaches to transitive verbs, such as *daxpü* ‘hug’ in (30), MPM also surfaces. Morphemes that show these patterns include other modal auxiliaries and aspectual auxiliaries (see Table 5). Their similarities in meaning and the fact that raising predicates found in other languages are often aspectual and modal is, I believe, not a coincidence. Rather they suggest that modal and aspectual auxiliaries in Crow are in fact raising predicates.

- (28) **baa-xalússhi-w-iimmaachi-k**  
 1A-run-1A-will-DECL  
 ‘I will run’
- (29) **bii-hachk-íimmaachi-k**  
 1B-tall-will-DECL  
 ‘I will be tall’
- (30) **dii-waa-laxpíi-w-iimmaachi-k**  
 2B-1A-hug-1A-will-DECL  
 ‘I will hug you’

In what follows, I propose an account in which MPM in Crow is analyzed as a type of clitic doubling. I adopt an analysis in particular in terms of A-movement and m-merger, following Harizanov (2014). Before turning to the analysis of MPM, it is instructive to first consider Harizanov’s account of clitic doubling in Bulgarian. Harizanov argues that clitic doubling in Bulgarian involves multiple spell-out of a single element in different structural positions as a result of A-movement. Under his analysis, an internal argument KP undergoes A-movement from its base-generated position to SpecvP (‘tucking in’ under the external KP argument), as in (31a)), to fulfill an EPP feature  $\nu$ , and then undergoes morphological restructuring (i.e. m-merger). When the displaced KP in SpecvP undergoes m-merger, it is reduced to its K head – comprised of Case- and  $\varphi$ -features – and is rebracketed as part of a complex  $\nu$  head, as in (31b)).<sup>21</sup> As a result, the K head, which resides within the complex head, is rendered invisible to the linearization algorithm; this point is crucial in ensuring that neither the KP in the base position (i.e. the associate) nor the K head (i.e. the clitic) within the verbal complex are deleted. On the other hand,

<sup>21</sup> Harizanov (2014: 1067) reformulates Matushansky’s (2006) original proposal of m-merger by allowing both branching and non-branching maximal projections to be rebracketed. In his revised version of m-merger, morphological restructuring of a branching maximal projection first reduces it to its head before deriving a new complex head. As will be clear below, I do not adopt his reformulation of m-merger in this paper.

if the moved element does not undergo m-merger, then only the c-commanding copy comes to be pronounced.

(31) a. Movement to Spec $\nu$ P

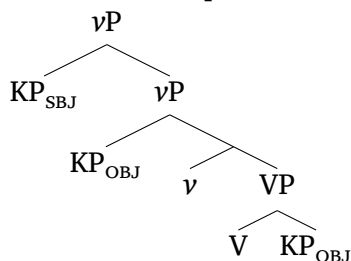

b. M-merger

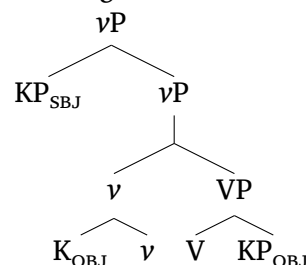

I argue that MPM (or clitic doubling of subjects) in Crow proceeds in a similar way to Harizanov's (2014) proposal of clitic doubling of objects in Bulgarian. To account for the raising constructions in (28) and (29), I assume that modal and aspectual auxiliaries in Crow reside in Aux and that both  $\nu$  and Aux are endowed with m-merger triggering properties. Furthermore, I assume these morphemes bear an EPP feature that requires the specifier of Aux to be filled. In an unergative, as in (32), movement to SpecAuxP occurs without issue: the external argument, the highest accessible DP argument of Aux, raises from its base position in Spec $\nu$ P to the landing site in SpecAuxP. However, in an unaccusative, as in (33), movement fails to occur.  $\nu$  is a phase head and accordingly, by the time when Aux is merged into the structure, its complement, VP, is ineligible for additional syntactic operations having already been sent to Spell-Out. Since VP (and its daughters) can no longer be the target for further operations, movement of the internal argument DP out of the VP is blocked. To satisfy the EPP feature on Aux, I assume a null expletive ( $\emptyset_{\text{EXPL}}$ ) is inserted into its specifier, which is analogous to the insertion of expletives *it* and *there* in English to fulfill the EPP feature on T.

(32)

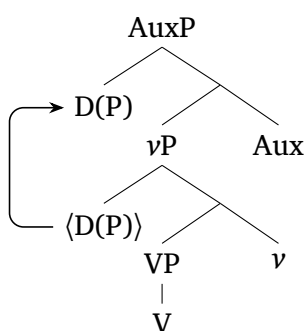

(33)

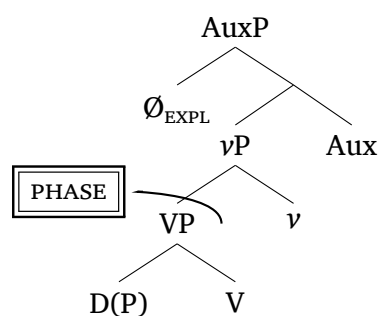

Ultimately, the occurrence of MPM is dependent on the syntactic position of the DP. In constructions with raising predicates, movement (and agreement) occurs only with unergative verbs but not unaccusatives.<sup>22</sup> For an unergative structure like (32), m-merger applies to Aux and  $\nu$  postsyntactically which rebrackets the higher and lower D copies as part of the complex heads. The result of this rebracketing is shown in (34). Recall in (25) that A-set morphemes are specified for both local person and nominative Case features. Because both D heads bear nominative Case features, both copies are spelled out as A-set. Therefore, under this view, MPM in Crow is a type of multiple copy spell-out phenomenon that is derived via A-movement.

<sup>22</sup> To my knowledge, I know of no other languages that displays an unergative/unaccusative split in the ability to undergo raising.

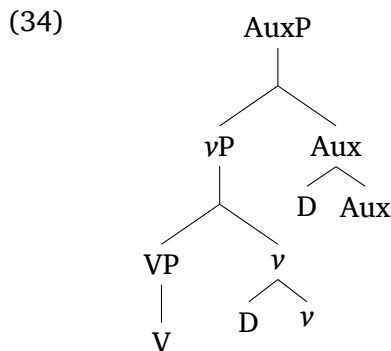

The order of operations in a structure consisting of an unergative verb root and a raising predicate is as follows. Aux bears uninterpretable (unvalued)  $\varphi$ -features, a nominative Case feature, and an EPP feature while the external argument has uninterpretable (unvalued) Case features and interpretable  $\varphi$ -features. Aux probes and forms an Agree relation with the highest element with  $\varphi$ -features – the DP residing in SpecvP. Consequently, Aux is valued with  $\varphi$ -features of the DP and assigns nominative Case to the DP. The nominative Case-marked DP then raises and merges with Aux, leaving behind a copy which also bears nominative Case. Postsyntactically, the higher and lower copies undergo m-merger and become part of the verbal complex. Finally, at Vocabulary Insertion, A-set morphemes are inserted as the spell out of local person and nominative Case features on the D heads. Note that neither the D head in the complex verbal head nor its associate in the base position are deleted as the former is rendered invisible to the linearization algorithm.

Although MPM only co-occurs with local person subjects, it is worth considering raising clauses that contain third person subjects. In Crow, A-set (and B-set) morphemes that index third person subjects are phonologically absent. As such, MPM is not directly observable for third person subjects. Moreover, in raising constructions with third person subjects, as in (35a), only a single nominal DP may be overtly expressed. Thus, how does the analysis sketched above extend to clauses with an overtly expressed third person subject DP nominal? An important distinction that I make is that pronominals undergo m-merger whereas full DP nominals do not. This stipulation follows from Matushansky's (2006) proposal of m-merger, which is a part of her reconceptualization of the mechanisms of syntactic head movement. In her original formulation, m-merger can take place for phrases only if they are simultaneously heads and maximal projections (Matushansky 2006: 83). As a result, when the subject DP raises to SpecAux, as shown in (35b), m-merger does not apply since the DP is not itself a head. Both copies reside in their associated A-positions, SpecvP and SpecAuxP, and at linearization, the lowest copy is deleted leaving the highest copy to be pronounced.<sup>23</sup>

- (35) a. Logan xalússh-iimmaachi-k  
 Logan run-will-DECL  
 'Logan will run'

<sup>23</sup> In Crow, third person DP subjects are often not expressed. In these cases, I assume that clitic doubling proceeds in the same way for local persons; that is, the third person pronominal also undergoes A-movement and m-merger. However, the vocabulary items for third-person A-set morphemes lack phonological content.

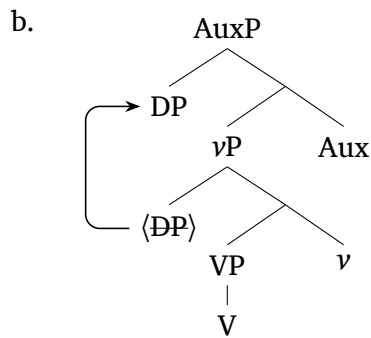

Under this analysis, the origins of the distinct agreement patterns between unergatives and unaccusatives lie in their structural differences. In simplex unergatives, the external argument is in a syntactic position that can be accessed by the Aux probe. In contrast, simplex unaccusatives contain an internal argument that is outside of Asp's search domain. This distinction is important because it is precisely interaction with Aux that determines whether A-set marking will occur. With raising predicates, movement enters into the picture but Aux is still the main driving force. Because subjects of unergatives are accessible to Aux, they undergo movement and each copy is eventually spelled out with an A-set marker. With unaccusatives, subject DPs do not interact with Aux and remain in their base position. As a result, raising constructions with unaccusatives display neither A-set marking nor multiple occurrences of A-set markers.

### 3.3 Control

I turn now to control constructions, which unlike raising, employ A-set morphemes to refer to subjects and exhibit MPM for both unergative and unaccusative verbs, as in (9) and (10) which are repeated in (36) and (37). The agreement patterns for control constructions are summarized in Table 7. For raising constructions, I proposed an account that brings to the forefront the structural differences between unergatives and unaccusatives. The argument I make for control in Crow is that there are in fact structural similarities in control clauses between unergatives and underlying unaccusatives. What I propose is that both kinds of structures consist of an argument DP in the specifier of  $vP$  which feeds A-set agreement and MPM.

(36) **baa-lisshí-wia<sub>2</sub>-waa-k**  
 1A-dance-DESID-1A-DECL  
 'I want to dance'

(37) **hachká-wee-wia<sub>2</sub>-waa-k**  
 tall-1A.INCHO-DESID-1A-DECL  
 'I want to be tall'

PROPERTY	CONTROL	
	ACTIVE	STATIVE
A-set references subjects?	✓	✓
Multiple person marking?	✓	✓

**Table 7:** Summary of agreement patterns in control clauses.

In (38), the sentence contains the suffix *-bia* with an unergative verb *disshí* ‘dance’. This construction is semantically ambiguous and may be interpreted with a futurate reading or a desiderative reading. Although both futurate and desiderative *-bia* appear to display similar morphosyntactic properties, I argue that the former involves a raising predicate while the latter involves a control predicate. Because clauses with futurate and desiderative *-bia* and unergative verbs are virtually indistinguishable, I turn to unaccusatives in search of evidence for the raising/control distinction.

- (38)    baa-lisshí-**wia**<sub>1/2</sub>-waa-k  
           1A-dance-going.to/DESID-1A-DECL  
           ‘I am going/want to dance’

In raising constructions of unaccusative verbs, raising predicates attach directly to the verbal root, as in (39). This is exemplified by (39a) with *-bia* ‘going to’ which suffixes onto the unaccusative verb *ámmít* ‘fall’. However, (39a) can only receive a futurate meaning but not a desiderative meaning. Directly attaching control predicates, such as the desideratives *-bia* and *-isshi* and the andative *-dee*, renders the sentence ungrammatical, as in (40). It is precisely this behavior that distinguishes raising from control predicates. Raising predicates may directly attach to unaccusatives but control predicates may not.

- (39)    a.    bii-ámmít-**bia**<sub>1</sub>-k  
                   1B-fall-going.to-DECL  
                   ‘I am going to fall’  
           b.    bii-ámmich-**iimmaachi**-k  
                   1B-fall-WILL-DECL  
                   ‘I will fall’  
           c.    bii-ámmít-**dahku**-k  
                   1B-fall-CONT-DECL  
                   ‘I keep on falling’
- (40)    a.    \*bii-ámmít-**bia**<sub>2</sub>-k  
                   1B-fall-DESID-DECL  
                   Intended: I want to fall  
           b.    \*bii-ámmich-**isshi**-k  
                   1B-fall-DESID-DECL  
                   Intended: I wish to fall  
           c.    \*bii-ámmít-**dee**-k  
                   1B-fall-go-DECL  
                   Intended: I went to fall

Is the ban on forming control predicates with unaccusatives semantic or is it syntactic? Perhaps the intended meaning of a sentence like ‘I want to fall’ is simply infelicitous in Crow and therefore not permitted. As we see in (41), this cannot be the case. In order to express control constructions with unaccusative verbs, the so-called inchoative marker *-dee* must be used.<sup>24</sup> I suggest that the source of the ungrammaticality in (40) is in fact

<sup>24</sup> The term ‘inchoative’ is borrowed from Graczyk (2007: 120) who also uses the gloss ‘become’ to interchangeably refer to *-dee*. Moreover, Wallace (1993: 139, fn.9) characterizes *-dee* as ‘volitional be/become’ based in part on her analysis that it creates an unergative out of an unaccusative. Outside the Crow literature, ‘inchoative’ is generally used to either express a beginning of a state or it can be used to indicate a change of state. Although the characterization of *-dee* as an inchoative may be incorrect, some of the meanings that arise from the use of *-dee* appear to fit the latter definition. First, *-dee*, which only occurs on stative verbs, typically co-occurs with desideratives or imperatives which are associated with a result state. Second, when it occurs in texts without a desiderative or imperative, it is often translated as ‘become’ or ‘get’.

syntactic, not semantic, in that the absence of *-dee* serves a necessary syntactic function (i.e. as a repair). In (41), the inchoative attaches close to the verbal root and inflects for person. In addition, multiple occurrences of A-set can be found in these constructions, one on the inchoative and one on the control predicate. Note that in these constructions, the B-set that usually indexes subjects in unaccusatives is obligatorily absent. Thus, the raising/control distinction emerges with unaccusatives but not with unergatives.

- (41) a. ámmit-**bee**-wia-**waa**-k  
 fall-1.INCHO-DESID-1A-DECL  
 ‘I want to fall’  
 b. ámmit-**bee**-w-**isshi**-k  
 fall-1.INCHO-DESID-1A-DECL  
 ‘I wish to fall’  
 c. ámmit-**bee**-**waa**-lee-k  
 fall-1.INCHO-1A-go-DECL  
 ‘I went to fall’

Why does the inchoative marker obligatorily co-occur in control constructions and how exactly does it feed the occurrence of MPM? Wallace (1993: 143) suggests that the inchoative *-dee* transforms unaccusatives to unergatives and “allows a predicate which otherwise assigns no agentive roles to be interpreted as having an agentive subject.” In other words, Wallace proposes that the inchoative brings about semantic and syntactic changes when it co-occurs with unaccusatives, as opposed to just a syntactic change as mentioned above. It is difficult to diagnose the precise functions of the inchoative since it often co-occurs with other morphemes and is restricted to unaccusatives. Nevertheless, I adopt Wallace’s proposal that the inchoative *-dee* converts an unaccusative into an unergative, as illustrated in (42). The structure in (42a) represents an unaccusative in which the DP subject is externally merged as the complement of V. When the inchoative attaches to the unaccusative, which I analyze as residing within  $v$ , it yields the structure (42b) in which the DP subject is instead externally merged with  $v$ .

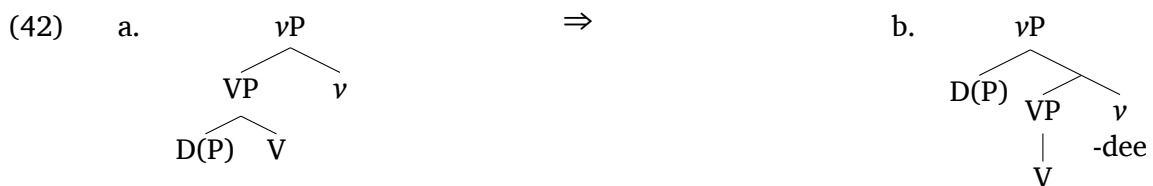

I consider the application of the inchoative in control constructions with unaccusative verbs as a repair strategy, which would otherwise yield an ungrammatical structure. Assuming that control predicates also reside in Aux and bear an EPP feature, movement in control constructions with unergatives is derived in much the same way as their raising counterpart. In (43), which represents a control clause with an unergative, the external argument moves to SpecAuxP, the same landing site for raising constructions. But in control clauses, this landing site is a theta-position. The structure of a control clause with an underlying unaccusative is diagrammed in (44). Since the inchoative creates an unergative out of an unaccusative, the derivation proceeds in exactly the same way – the external argument DP raises to SpecAuxP followed by m-merger and multiple copy spell-out.

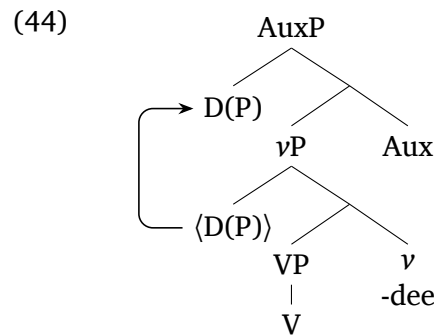
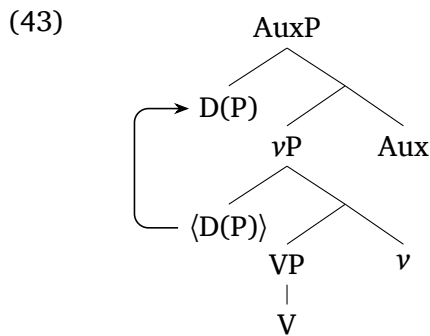

Now, consider the scenario in which the inchoative is absent from control constructions of unaccusatives. It would look similar to their raising analog. Movement of the DP element out of VP to SpecAuxP would be blocked for the same reason why raising constructions of unaccusatives do not display MPM;  $v$  is a phase head and movement of the DP out of VP would violate PIC. The structure with this illicit A-movement is given in (45). Without an accessible DP, the structure would fail to satisfy the EPP feature on Aux. While raising constructions repairs this pernicious scenario by inserting a null expletive, control constructions are unable to do so because (null) expletives are unable to receive a theta-role.

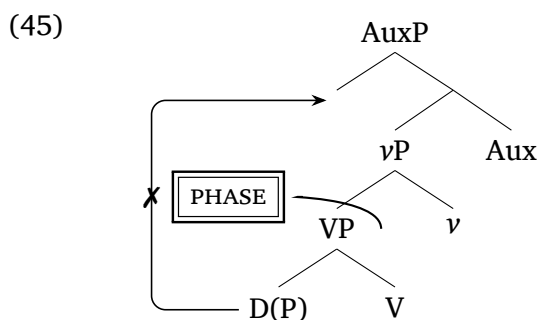

Moreover, the inchoative *-dee* does not occur in raising constructions of unaccusatives, but why exactly should this be? If the VP-internal DP is unable to be extracted out of the phase, we might expect *-dee* to similarly act as a repair. Instead of inserting a null expletive, the inchoative creates an unergative from the unaccusative allowing for the subject DP to raise to the specifier position of Aux to satisfy its EPP feature, as in (44). My proposal draws on the fact that control predicates in Crow must locally assign a theta-role to a DP argument; in contrast, raising predicates do not assign a theta-role to their argument. Inserting a null expletive, which cannot receive a theta-role, as a repair presents no issue in raising constructions, but in control clauses, it is insufficient. The solution that is adopted in Crow is to recruit the inchoative to convert an unaccusative into an unergative which subsequently allows a DP to move into SpecAuxP where it is assigned a theta-role.

With aspectual triggers of MPM, only unergatives participate in MPM. But with desiderative triggers, all intransitive verbs participate. I have argued that this is because aspectual suffixes trigger raising, whereas desiderative suffixes trigger control. The differences between raising and control of unergatives in Crow therefore appear imperceptible. Both constructions display A-set agreement and both exhibit MPM. Only when we direct our attention to unaccusatives can we detect differences in behaviors between raising and control. In raising constructions, A-set agreement and MPM are restricted to unergative verbs and I have proposed an account that taps into the differences in argument

structure. In control constructions, this distinction becomes neutralized and I have provided an analysis in which the positions of core arguments in control constructions of unergatives and unaccusatives are actually identical. In the following sections, I turn to causative constructions that also neutralize this distinction, and argue that structural similarities and restrictions on Agree, a subcomponent of movement, continue to play a vital role.

#### 4 The structure of causatives

In Crow, there are two causative morphemes. The direct (or ‘lexical’) causative *-aa*, which is relatively unproductive, is restricted to unaccusatives, while the indirect causative *-hche* may combine with any verb. Although both causatives introduce an external argument into the clause, usually an agent or a causer, there is a number of semantic differences between the uses of the two morphemes. Differences in meaning can be readily observed in minimal pairs where each causative morpheme occurs on the same stem (Graczyk 2007: 325-6, Ex.110):

- (46) a. bas-ílaalee xachíi-w-**aa**-k  
 1POS-car move-1A-CAUS-DECL  
 ‘I moved my car (e.g., by pushing it)’  
 b. bas-ílaalee xachíi-wa-**hche**-k  
 1POS-car move-1A-CAUS-DECL  
 ‘I moved my car (e.g., by turning the ignition key and starting the engine)’

The sentences in (46) contain the unaccusative verb *xachíi* ‘be moved, feel movement’. In (46a), the use of the direct causative suggests that the agent, which is introduced by the causative, exerts energy to bring about the result intentionally and directly. In (46b), the causer, which is introduced by the indirect causative, achieves similar results but through an intermediary – the engine. By turning the ignition key, the causer starts the engine which converts the energy from the heat of burning gasoline into mechanical torque – and thus the car is set in motion.

Another semantic difference observed between the two causative morphemes involves animacy. In general, the direct causative strongly suggests an animate agent. A plausible explanation is that the direct causative expresses agency which tends to imply animate entities. Direct/indirect causative minimal pairs involving an animate and inanimate subject are given in (47) and (48), respectively. In (47), the first person animate subject can be used with either causative marker. In contrast, we find that when the subject is inanimate, such as *microwave* in (48a), its co-occurrence with direct causative is rendered infelicitous.<sup>25</sup>

- (47) a. xóoxaashe tawée-w-aa-k  
 corn hot-1A-CAUS-DECL  
 ‘I heat up the corn’

<sup>25</sup> Direct affixation of Crow morphology onto insertions of English nouns is generally not permitted. To add Crow morphology onto English nouns within a Crow matrix frame, the element *kooté* must co-occur with the inserted noun to form the base onto which Crow nominal morphology may be added. This appears to be a nominal counterpart to insertions of English verbs in Crow in which the ‘helping’ or light verb *kootá*, which has the same underlying form as *kooté*, accompanies the inserted verbal element. These so-called light verb constructions have been more widely reported in other contact situations involving code-switching, such as Navajo-English (Canfield 1980), Marathi-English (Joshi 1982), Hindi-English (Ritchie & Bhatia 1999), Japanese-English (Azuma 1997), among many others.

- b. xóoxaashe tawée-wa-hche-k  
 corn hot-1A-CAUS-DECL  
 ‘I heat up the corn’
- (48) a. %microwave kooté xóoxaashe tawée-a-k  
 microwave like.that corn hot-CAUS-DECL  
 Intended: the microwave heat up the corn
- b. microwave kooté xóoxaashe tawée-hche-k  
 microwave like.that corn hot-CAUS-DECL  
 ‘the microwave heat up the corn’

Despite these semantic differences, the direct and indirect causative constructions exhibit a number of morphosyntactic similarities, which are summarized in Table 8. Crucially, both causative morphemes, when attached to any verb, display A-set agreement to index the DP they introduce, as in (47); cf. *xóoxaashe tawéek* ‘the corn is hot’). When formed with raising and control predicates, direct and indirect causative constructions will also exhibit multiple person marking (MPM) with *bia*, as in (49a) and (49b), respectively.

**Table 8:** Summary of agreement patterns in causative clauses.

PROPERTY	CAUSATIVES	
	ACTIVE	STATIVE
A-set references subjects?	✓	✓
Multiple person marking?	✓	✓

- (49) a. xóoxaashe óosh-**b**-aa-wia<sub>1/2</sub>-**waa**-k  
 corn cook-1A-CAUS-going.to-1A-DECL  
 ‘I’m going/want to cook the corn’
- b. dii-hachká-**wa**-hche-wia<sub>1/2</sub>-**waa**-k  
 2B-fall-1A-CAUS-going.to-1A-DECL  
 ‘I’m going/want to make you to be tall’

In light of the fact that the direct causative marker attaches to unaccusatives to introduce an external argument, I assume that the direct causative is housed within *v*. On the other hand, the indirect causative may attach to any verb and I assume a bipartite structure comprised of not only a *v* layer that introduces an external argument, but also a Caus(ative) layer below it that yields causative semantics (Pylkkänen 2008; 2002). The structures involving the direct and indirect causatives are given in (50a) and (50b), respectively. In both structures, the DPs that are introduced by the causative morphemes are not only accessible to the probe on Aux, but they are the *closest* accessible DPs. Thus, A-set agreement in causative constructions always cross-references the arguments introduced by the causative markers.

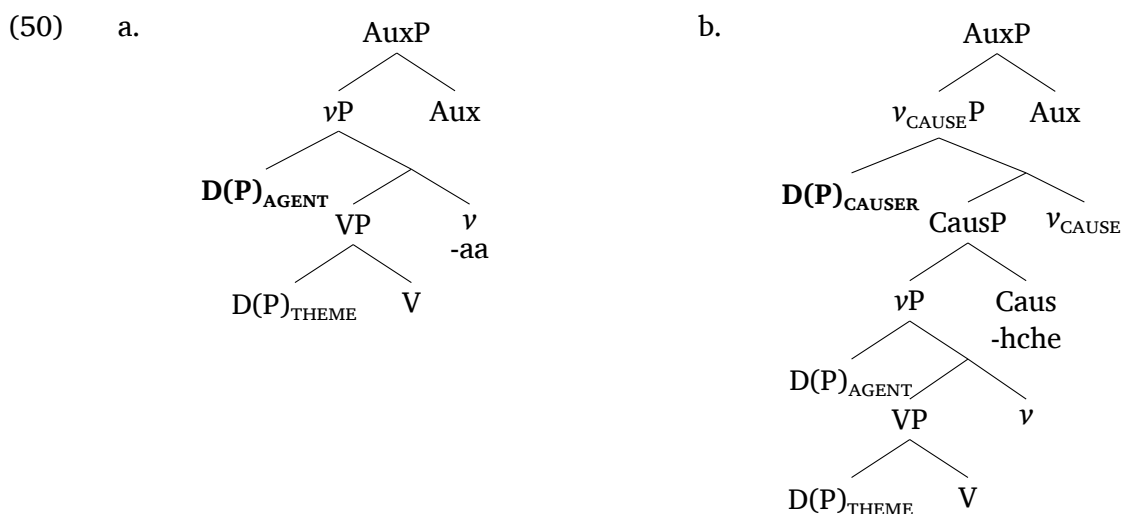

#### 4.1 Direct causative constructions

The direct causative is generally restricted to unaccusative verbs to introduce an agent into the clause.<sup>26</sup> A simplex unaccusative with the verb *óosshi* ‘be cooked’ and subject *xóoxaashe* ‘corn’ is given in (51a). With the direct causative, the subject of the clause is an agent, as in (51b), and the A-set morpheme reflects the person feature of the agentive argument. In (51c), the raising predicate *-bia<sub>1</sub>* ‘going to’ is added and we obtain two instances of A-set agreement. By applying the direct causative, not only does A-set morphology surface, but in the presence of a MPM trigger, multiple A-set morphemes surface.

- (51) a. *xóoxaashe óosshi-k*  
 corn cook-DECL  
 ‘The corn is cooked’
- b. *xóoxaashe óosh-b-aa-k*  
 corn cook-1A-CAUS-DECL  
 ‘I cooked the corn’
- c. *xóoxaashe óosh-b-aa-wia<sub>1/2</sub>-waa-k*  
 corn cook-1A-CAUS-going.to/DESID-1A-DECL  
 ‘I’m going/want to cook the corn’

As mentioned above, I assume that the direct causative morpheme resides within the *v* head which introduces an agent DP into its specifier. The VP-internal theme DP is unaffected and remains in-situ. The structures of (51b) and (51c) are given in (52a) and (52b), respectively. Introducing an external argument into the structure has two important consequences. First, Aux can now probe a DP element; with plain unaccusatives, Aux is unable to access the VP-internal DP. By interacting with the external argument, the DP receives nominative Case, a prerequisite for the occurrence of A-set agreement. The second consequence is that with raising and control predicates, the external argument can now also move to SpecAux which allows for multiple copy spell-out and results

<sup>26</sup> According to Gordon & Graczyk (n.d.), there is a single exception involving the active intransitive verb *xii* ‘move (in a direction)’ which may combine with the direct causative *-aa*. However, this verb does not occur independently. I postulate that the combination of *xii* with *-aa* underwent lexicalization, resulting in a transitive verb in contemporary Crow that is no longer decomposable.

in the multiple occurrence of A-set morphemes. Thus, the facts about MPM once again fall out from an account that critically relies on A-movement and m-merger.

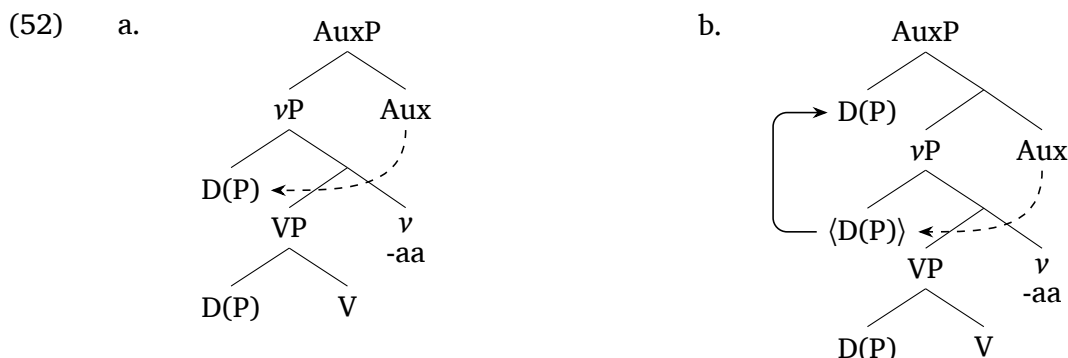

#### 4.2 Indirect causative constructions

Let us first consider what happens when we add an indirect causative to a transitive verb. A simplex transitive construction is given in (53a). Here, the A-set morpheme cross-references the first-person subject, whereas the B-set morpheme indexes the second-person object. The constructions in (53b) and (53c) are causativized transitives with the same verb.<sup>27</sup> In (53b), the second-person causer is indexed with the A-set morpheme *-da* that is inflected onto the indirect causative marker. In Crow, third-person is phonologically null, so the first-person B-set marker *bii-* can either refer to the ‘hitter’ or the ‘hittee’. Under the former reading, the agent of the main verb is referenced not with an A-set marker, but with with a B-set. This becomes more apparent in (53b) in which the core arguments of the verb *dichí* ‘hit’ are both indexed via B-set. Thus, the main generalization in (53) is that in simplex transitive clauses, A-set indexes the subject – the agent. However, when with causativized transitives, A-set must index the causer. All other arguments are referenced via B-set.

- (53) a. *dii-waa-lichí-k*  
2B-1A-hit-DECL  
‘I hit you’
- b. *Logan bii-lít-da-hche-k*  
Logan 1B-hit-2A-CAUS-DECL  
‘you made me hit Logan’ / ‘you made Logan hit me’
- c. *Logan dii-wii-lichí-hche-k*  
Logan 2B-1B-hit-CAUS-DECL  
‘Logan made me hit you’ / ‘Logan made you hit me’

The main generalization of (53) can be captured under an account where the indirect causative marker sits above active and non-active *vP*. The structure in (54) represents a causativized transitive clause. The indirect causative is comprised of two layers –  $v_{\text{CAUS}}$  and Caus – wedged between *vP* and AuxP. The  $v_{\text{CAUS}}$  head introduces the causative argument into its specifier which becomes the target of Aux and receives nominative Case; this newly introduced DP is not only accessible, but is also the closest DP to the probe on Aux. Moreover, I assume that  $v_{\text{CAUS}}$  is a  $\varphi$ -probe that targets the closest accessible DP

<sup>27</sup> According to Wallace (1993: 86-87) and Graczyk (2007: 199-200), B-set morphemes enjoy a great deal of freedom in terms of their ordering. Accordingly, (53c) is considered ambiguous – the first person B-set morpheme *dii-* can either refer to the ‘hitter’ or the ‘hittee’.

within its search domain – the agentive DP in SpecvP. Finally, the  $v$  probe locates and agrees with the theme inside the VP. Thus, the only argument to receive nominative Case is the causer which is therefore the only argument that is cross-referenced via A-set.

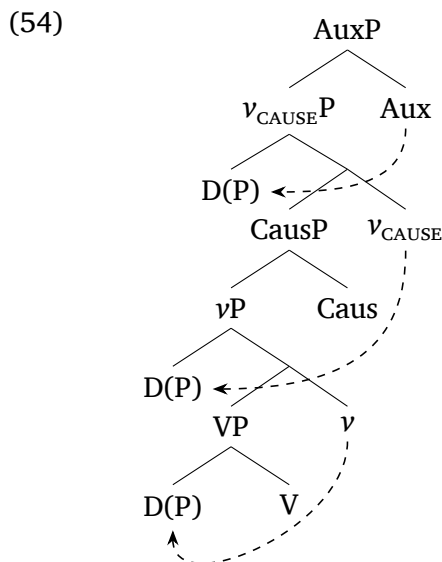

I have argued that A-set agreement is intimately linked to the probe on Aux having direct access to a DP argument. However, this is insufficient. Assuming  $v_{\text{CAUSE}}$  does not constitute a phase, then in (54), there are two DP arguments within the search domain of Aux: the causer and the agent. But A-set morphology is used to refer to the causer. What seems to also matter is not just accessibility of the DP, but also its relative position within the clausal spine. The causer is situated higher than the agent, so Aux must not only be concerned with accessible DPs, but also its relative position within the clausal spine. The causer is situated higher than the agent, so Aux must not only be concerned with accessible DPs. Rather, Aux cares about the *highest accessible* DP – the classic case of locality of Agree. We can also see how this proposal handles unergatives and unaccusatives that co-occur with the indirect causative, as in (55a) and (55b). In these two constructions, the active-stative agreement distinction between the two intransitives is neutralized and the A-set morpheme refers only to the causative argument; all other arguments receive B-set marking. If the DP that is introduced by the indirect causative is the highest accessible DP, then it follows that it should be referenced using A-set morphology.

- (55) a. dii-chiwakíi-wa-hche-k  
 2B-pray-1A-CAUS-DECL  
 ‘I made you pray’  
 b. dii-ámmit-ba-hche-k  
 2B-fall-1A-CAUS-DECL  
 ‘I made you fall’

I turn now to causative constructions with raising and control predicates. While the analysis below focuses on the control predicate *-bia<sub>2</sub>* ‘want to’, it extends to other control and raising predicates that follow the indirect causative. The control equivalent of (55) is given in (56). With unergatives and unaccusatives, A-set morphemes are multiply realized on the indirect causative and the desiderative. It is important to also note that even with an unaccusative verb, the inchoative is no longer required. The structural configurations of (56) are displayed in (57).

- (56) a. *dii-chiwakíi-wa-hche-wia<sub>2</sub>-waa-k*  
 2B-pray-1A-CAUS-DESID-1A-DECL  
 ‘I want you to pray’  
 b. *dii-ámmit-ba-hche-wia<sub>2</sub>-waa-k*  
 2B-fall-1A-CAUS-DESID-1A-DECL  
 ‘I want you to fall’

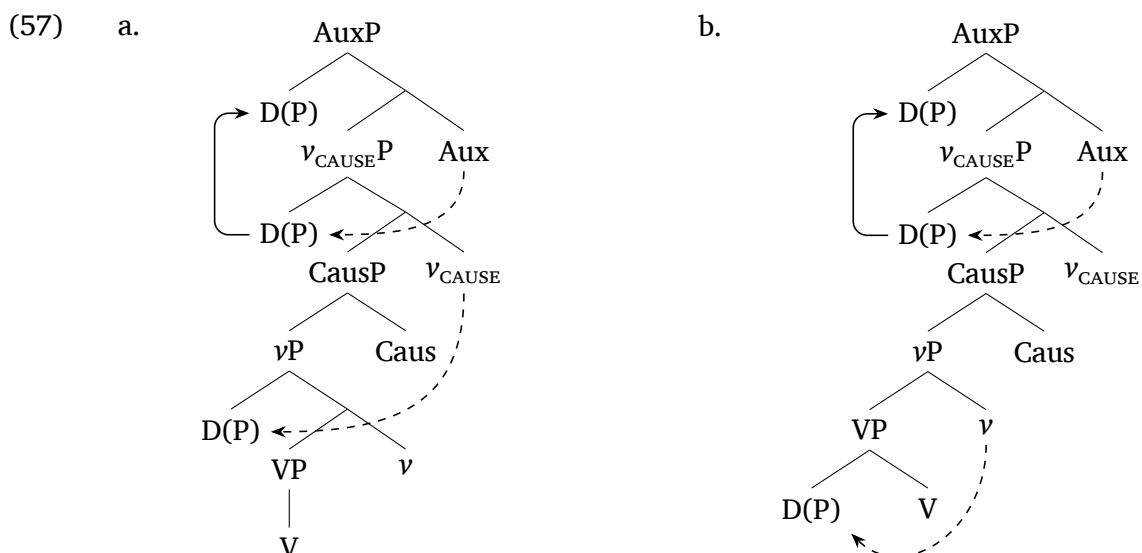

Under a clitic doubling analysis of MPM, the patterns observed in (56) can be accounted for in a straightforward manner. In both structures presented in (57), the  $v_{\text{CAUSE}}$  head introduces an external argument. As I have discussed above, this argument, by virtue of being introduced in a position higher than all other arguments in the clause, is the highest accessible DP element for Agree with Aux. The causative DP agrees with Aux, receives nominative Case, moves to its specifier where it receives a theta-role and fulfills the [EPP] feature on Aux. The higher and lower copies of the causative DP, which bears a [NOM] feature, undergo m-merger and are then eventually pronounced as A-set markers. The point about the assignment of theta-roles in the specifier of Aux that occurs in the two structures is important. The inchoative, which obligatorily co-occurs with unaccusatives in control clauses, is notably absent in (56b), which contains an unaccusative. I have argued that the inchoative acts as a repair strategy when there are no DP arguments that can move into the specifier of Aux to receive a theta-role. Because the argument introduced by the indirect causative is able to move into SpecAux, an inchoative is no longer needed as a repair.

## 5 Conclusion

In this paper, I have argued that Crow, a highly polysynthetic language, displays a number of raising and control constructions. The central claims of the analysis comes from two main arguments: (a) multiple person marking is derived from A-movement and m-merger, and (b) the inchoative *-dee* acts a repair strategy for allowing theta-roles to be marked on subjects of underlying unaccusatives.

The specific analysis of the Multiple Person Marking Generalization considers the occurrence of multiple A-set markers as a type of clitic doubling phenomenon, decomposed

into two parts: A-movement and m-merger. To account for the agreement split between unergatives and unaccusatives in the realization of A-set markers in raising constructions, I proposed an analysis in which subjects of unergatives may raise from SpecvP into SpecAuxP to satisfy the EPP, whereas subjects of unaccusatives must remain in-situ. In raising constructions with unaccusatives, A-movement out of the VP-internal base position would violate the PIC; instead, a null expletive is inserted into SpecAuxP to satisfy the EPP. Therefore, the occurrence of A-set agreement and multiple person marking is conditioned on whether A-movement of the DP argument to the higher landing site is permitted. In control clauses, which neutralize the agreement distinction in unergatives and unaccusatives, evidence that distinguishes them from raising comes from unaccusatives. In control of underlying unaccusatives, the inchoative *-dee* obligatorily attaches to the verb root and functions as a repair by allowing subjects of underlying unaccusatives to receive a theta-role from the control predicate – the ability to assign theta-role is a distinguishing feature of control predicates. Finally, I have shown that the analysis of raising and control can be straightforwardly extended to causative constructions, which also neutralize the agreement distinctions between unergatives and unaccusatives. In causative constructions, a (highest) external argument is introduced and serves as the target for clitic doubling. Since the causative external argument is the highest accessible DP for the Aux probe, it undergoes A-movement. Under this view, multiple person marking crucially involves A-movement, which helps to paint a clearer picture of the mechanisms that underlie raising and control constructions in Crow.

Identifying control and raising in polysynthetic languages is a non-trivial task. Some of the classic diagnostics of control and raising rely heavily on properties that are associated with biclausal constructions. In addition, evidence for A-movement is not always easy to come by in languages with a high degree of polysynthesis. The Crow picture presented here is just one way in how control and raising manifest in these types of languages. In particular, studying the distribution of agreement markers or pronominals across a variety of clauses, such as those with meanings often attributed to control and raising in other languages, may reveal important insights about the true nature of these clauses. In this paper, I have analyzed A-set agreement markers as pronouns. In some sense, this is desirable since we can come to see how control in Crow shares similarities with other languages, such as San Lucas Quivini Zapotec. In Crow and San Lucas Quivini Zapotec, pronouns that reference controller and controllee must be overtly pronounced. In contrast to control in San Lucas Quivini Zapotec, however, in which controller and controllee nominal DPs may both be expressed, at most one nominal may be overtly expressed in Crow. Thus, the properties of raising and control in Crow contribute to our understanding of the possible typological space of raising and control. Future work investigating control and raising in polysynthetic languages may find that studying the behavior of agreement and pronominals is a fruitful endeavor.

## Abbreviations

1 = first person, 2 = second person, 3 = third person, A = active agreement, B = stative agreement, CAUS = (in)direct causative, CONT = continuative, DECL = declarative, DESID = desiderative, INCHO = inchoative, IRR = irrealis, JUNCT = juncture morpheme, OBJ = object, textscsbj = subject, and SS = same-subject.

## Acknowledgements

[Placeholder]

## References

- Albright, Adam C. 2002. *The identification of bases in morphological paradigms*: University of California, Los Angeles dissertation.
- Alexiadou, Artemis, Elena Anagnostopoulou, Gianina Iordachioaia & Mihaela Marchis. 2010. No objections to backward control. *Movement theory of control* 89–118. <https://doi.org/10.1075/la.154.04ale>.
- Asudeh, Ash & Ida Toivonen. 2012. Copy raising and perception. *Natural Language & Linguistic Theory* 30(2). 321–380. <https://doi.org/10.1007/s11049-012-9168-2>.
- Author. 2019. Unaccusativity in Crow. In *Proceedings of the 39th annual siouan and caddoan languages conference*. 83–101.
- Azuma, Shoji. 1997. Lexical categories and code-switching: A study of Japanese/English code-switching in Japan. *The Journal of the Association of Teachers of Japanese* 31(2). 1–24. <https://doi.org/10.2307/489656>.
- Bobaljik, Jonathan David & Idan Landau. 2009. Icelandic control is not A-movement: The case from case. *Linguistic Inquiry* 40(1). 113–132. <https://doi.org/10.1162/ling.2009.40.1.113>.
- Boeckx, Cedric. 2000. A note on contraction. *Linguistic Inquiry* 31(2). 357–366. <https://doi.org/10.1162/002438900554389>.
- Boeckx, Cedric & Norbert Hornstein. 2003. Reply to “Control is not movement”. *Linguistic Inquiry* 34(2). 269–280. <https://doi.org/10.1162/002438903321663406>.
- Boeckx, Cedric & Norbert Hornstein. 2004. Movement under Control. *Linguistic Inquiry* 35(3). 431–452. <https://doi.org/10.1162/0024389041402625>.
- Boeckx, Cedric & Norbert Hornstein. 2006. The virtues of control as movement. *Syntax* 9(2). 118–130. <https://doi.org/10.1111/j.1467-9612.2006.00086.x>.
- Boeckx, Cedric, Norbert Hornstein & Jairo Nunes. 2008. Copy-reflexive and copy-control constructions: A movement analysis. *Linguistic Variation Yearbook* 8(1). 61–100. <https://doi.org/10.1075/livy.8.03boe>.
- Boeckx, Cedric, Norbert Hornstein & Jairo Nunes. 2010. *Control as movement*, vol. 126. Cambridge University Press. <https://doi.org/10.1017/cbo9780511761997>.
- Canfield, Kip. 1980. Some Notes on Code Switching in Navajo. *Anthropological Linguistics* 22. 218–220.
- Chomsky, Noam. 1981. *Lectures on government and binding*. Dordrecht: Foris.
- Chomsky, Noam. 1993. A Minimalist Program for Linguistic Theory. *The view from Building 20: Essays in linguistics in honor of Sylvain Bromberger* <https://doi.org/10.7551/mitpress/9780262527347.003.0003>.
- Chomsky, Noam. 2000. Minimalist Inquiries: The Framework. *Step by step: Essays on minimalist syntax in honor of Howard Lasnik* 89–155.
- Chomsky, Noam. 2001. Derivation by Phase. In Michael Kenstowicz (ed.), *Ken Hale: A life in language*, 1–52. Cambridge, MA: MIT Press. <https://doi.org/10.7551/mitpress/4056.003.0004>.
- Clem, Emily. 2019. Object-sensitive switch-reference and insatiable probes. In Maggie Baierd & Jonathan Pesetsky (eds.), *NELS 49: Proceedings of the Forth-Ninth Annual Meeting of the North East Linguistic Society*, vol. 1. 173–186.

- Culicover, Peter W & Ray Jackendoff. 2001. Control is not movement. *Linguistic Inquiry* 32(3). 493–512. <https://doi.org/10.1162/002438901750372531>.
- Culicover, Peter W & Ray Jackendoff. 2006. Turn over control to the semantics! *Syntax* 9(2). 131–152. <https://doi.org/10.1111/j.1467-9612.2006.00085.x>.
- Deal, Amy Rose. 2009. The origin and content of expletives: Evidence from “selection”. *Syntax* 12(4). 285–323. <https://doi.org/10.1111/j.1467-9612.2009.00127.x>.
- Deal, Amy Rose. 2020. Interaction, Satisfaction, and the PCC. Ms. University of California, Berkeley.
- Gordon, Ray & Randolph Graczyk. n.d. A dictionary of Crow. Ms.
- Graczyk, Randolph. 1996. On ablaut in Crow. In *Annual Meeting of the American Anthropologist Association*. San Francisco, CA.
- Graczyk, Randolph. 2007. *A grammar of Crow*. University of Nebraska Press.
- Haddad, Youssef A. 2007. *Adjunct control in telugu and assamese*: University of Florida dissertation.
- Haddad, Youssef A. 2009. Copy control in Telugu. *Journal of linguistics* 69–109. <https://doi.org/10.1017/s0022226708005525>.
- Harizanov, Boris. 2014. Clitic doubling at the syntax-morphophonology interface. *Natural Language & Linguistic Theory* 32(4). 1033–1088. <https://doi.org/10.1007/s11049-014-9249-5>.
- Harris, Alice. 2017. *Multiple exponence*. Oxford University Press. <https://doi.org/10.1093/acprof:oso/9780190464356.001.0001>.
- Hornstein, Norbert. 1999. Movement and control. *Linguistic Inquiry* 30(1). 69–96.
- Hornstein, Norbert. 2001. *Move! : A minimalist theory of construal*. Blackwell Oxford.
- Hornstein, Norbert. 2003. On control. *Minimalist syntax* 6–81. <https://doi.org/10.1002/9780470758342.ch1>.
- Hornstein, Norbert & Maria Polinsky. 2010. *Movement Theory of Control*, vol. 154. John Benjamins Publishing. <https://doi.org/10.1075/la.154>.
- Jones, A Wesley. 1992. The “Hidatsa” Approximative”: Morphology, Phonology, Semantics: And an Approximate Look at Ablaut. *Anthropological Linguistics* 324–337.
- Joshi, Aravind. 1982. Processing of sentences with intra-sentential code-switching. In *Coling 1982: Proceedings of the Ninth International Conference on Computational Linguistics*.
- Kasak, Ryan. 2019. *Affix ordering and templatic morphology in Mandan*: Yale University dissertation.
- Kissock, Madelyn J. 2014. Evidence for ‘finiteness’ in Telugu. *Natural Language & Linguistic Theory* 32(1). 29–58. <https://doi.org/10.1007/s11049-013-9214-8>.
- Kramer, Ruth. 2014. Clitic doubling or object agreement: The view from Amharic. *Natural Language & Linguistic Theory* 32(2). 593–634. <https://doi.org/10.1007/s11049-014-9233-0>.
- Landau, Idan. 2003. Movement out of control. *Linguistic Inquiry* 34(3). 471–498. <https://doi.org/10.1162/002438903322247560>.
- Landau, Idan. 2007. Movement-resistant aspects of control. In *New Horizons in the Analysis of Control and Raising*, 293–325. Springer. [https://doi.org/10.1007/978-1-4020-6176-9\\_14](https://doi.org/10.1007/978-1-4020-6176-9_14).
- Landau, Idan. 2013. *Control in generative grammar: A research companion*. Cambridge University Press. <https://doi.org/10.1017/cbo9781139061858>.
- Lee, Felicia. 2003. Anaphoric R-expressions as bound variables. *Syntax* 6(1). 84–114. <https://doi.org/10.1111/1467-9612.00057>.

- Legate, Julie Anne. 2003. Some interface properties of the phase. *Linguistic Inquiry* 34(3). 506–515. <https://doi.org/10.1162/ling.2003.34.3.506>.
- Matushansky, Ora. 2006. Head movement in linguistic theory. *Linguistic Inquiry* 37(1). 69–109. <https://doi.org/10.1162/002438906775321184>.
- Mithun, Marianne. 1991. Active/agentive case marking and its motivations. *Language* 67(3). 510–546. <https://doi.org/10.2307/415036>.
- Nunes, Jairo. 1995. *The Copy Theory of movement and linearization of chains in the Minimalist Program*: University of Maryland, College Park dissertation.
- Nunes, Jairo. 1999. Linearization of chains and phonetic realization of chain links. *Working Minimalism* 32. 217–250. <https://doi.org/10.7551/mitpress/7305.003.0011>.
- Nunes, Jairo. 2004. *Linearization of Chains and Sideward Movement*, vol. 43. MIT press. <https://doi.org/10.7551/mitpress/4241.001.0001>.
- Park, Indrek. 2012. *A grammar of Hidatsa*: Indiana University dissertation.
- Polinsky, Maria. 2013. Raising and control. *Cambridge Handbook of Generative Syntax*, the <https://doi.org/10.1017/cbo9780511804571.021>.
- Polinsky, Maria & Eric Potsdam. 2002. Backward control. *Linguistic Inquiry* 33(2). 245–282. <https://doi.org/10.1162/002438902317406713>.
- Polinsky, Maria & Eric Potsdam. 2006. Expanding the scope of control and raising. *Syntax* 9(2). 171–192. <https://doi.org/10.1111/j.1467-9612.2006.00090.x>.
- Potsdam, Eric & Youssef A Haddad. 2017. Control phenomena. *The Wiley Blackwell Companion to Syntax, Second Edition* 1–29. <https://doi.org/10.1002/9781118358733.wbsyncom057>.
- Potsdam, Eric & Maria Polinsky. 2012. Backward raising. *Syntax* 15(1). 75–108. <https://doi.org/10.1111/j.1467-9612.2011.00158.x>.
- Potsdam, Eric & Jeffrey Runner. 2001. Richard returns: Copy raising and its implications. *Proceedings of Chicago Linguistic Society* 37. 453–468.
- Pylkkänen, Liina. 2002. *Introducing arguments*: MIT dissertation.
- Pylkkänen, Liina. 2008. *Introducing arguments*. MIT press. <https://doi.org/10.7551/mitpress/9780262162548.001.0001>.
- Rankin, Robert L. 1995. On Quapaw (and Siouan) ablaut. In *15th Annual Siouan and Caddoan Languages Conference*. University of New Mexico: Albuquerque, NM.
- Ritchie, William C. & Tej K. Bhatia. 1999. Codeswitching, grammar, and sentence production. In *The development of second language grammars*, 269. John Benjamins Publishing Company. <https://doi.org/10.1075/lald.18.14rit>.
- Shaw, Patricia A. 1980. *Theoretical issues in Dakota phonology and morphology*, vol. 20. Routledge. <https://doi.org/10.4324/9780429466502>.
- Ullrich, Jan. 2011. *Lakota grammar handbook: a pedagogically orientated self-study reference and practice book for beginner to upper-intermediate students*. Lakota Language Consortium, Bloomington, IN.
- Ura, Hiroyuki. 1998. Checking, economy, and copy-raising in Igbo. *Linguistic Analysis* 28(1/2). 67–88.
- Wallace, Karen Kay. 1993. *Verb incorporation and agreement in crow*: University of California, Los Angeles dissertation.
- Wood, Jim. 2012. Against the movement theory of control: Another argument from Icelandic. *Linguistic Inquiry* 43(1). 322–330. [https://doi.org/10.1162/ling\\_a\\_00089](https://doi.org/10.1162/ling_a_00089).